



# BELL HOUSING ASSEMBLY BH

ENGINEERING

1

Ref. No. P06634

Release 02/2005

## Description

The bell housing series BH are designed for coupling hydraulic pumps having ISO flanges to electric motors having metric flanges.

These bell housing are precisely machined to reduce misalignment of coupled shafts. The correct alignment of the shafts along with the cushioned power transmission through a resilient spider increase the life of the bearings of the pump/motor coupled.

The construction also reduces the noise generation considerably.



## Section

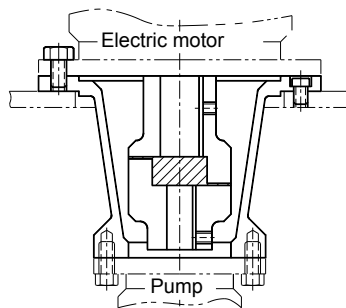

Hydraulic Symbol



## Unit dimension

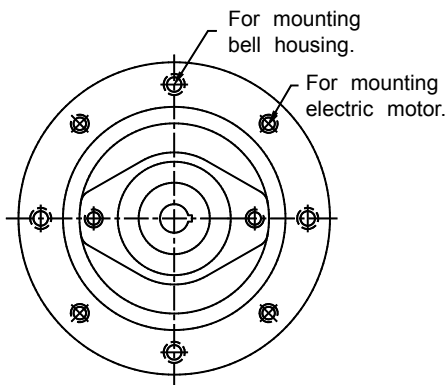

Dimensions in mm.

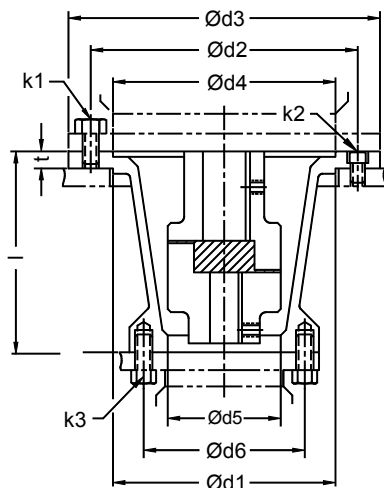
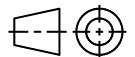

Pump mtg. flange.	Electric motor hp.	Ø d1	Ø d2	Ø d3	Ø d4	Ø d5	Ø d6	t1	l	k1 x nos. ( Hex )	k2 x nos. ( SHCS )	k3 x nos. ( Hex )
B1 flange	1-2	130	165	200	130	82.6	106.2	16	135	M10x4	M10x4	M10x2
	3-5	180	215	250	180			16	145	M12x4	M10x4	M10x2
	7.5-10	230	265	300	230			16	170	M12x4	M10x4	M10x2
	12.5-30	250	300	350	250			20	210	M16x4	M12x4	M10x2
B2 flange	1-2	130	165	200	130	101.6	146	16	145	M10x4	M10x4	M12x2
	3-5	180	215	250	180			16	145	M12x4	M10x4	M12x2
	7.5-10	230	265	300	230			16	175	M12x4	M10x4	M12x2
	12.5-30	250	300	350	250			20	210	M16x4	M12x4	M12x2
B3 flange	1-2	-	-	-	-	127	181	-	-	-	-	-
	3-5	180	215	250	180			16	175	M12x4	M10x4	M16x2
	7.5-10	230	265	300	230			16	195	M12x4	M10x4	M16x2
	12.5-30	250	300	350	250			20	225	M16x4	M12x4	M16x2

**Polyhydron Pvt. Ltd.**

78-80, Machhe Industrial Estate,  
Machhe, Belgaum - 590 014. INDIA.

Phone : +91-(0)831-2411001

Fax : +91-(0)831-2411002

E-mail : polyhydron@vsnl.com

Internet : www.polyhydron.com



# BELL HOUSING ASSEMBLY BH

ENGINEERING

2

Ref. No. P06634

## Technical specification

- Construction ..... Partially enclosed cast iron housing with flexible coupling.
- Mounting style ..... Flange mounting, factory standard.
- Mounting position ..... Axis of the assembly can be mounted in any direction.
- Pump mounting flange ..... As per ISO 3019/1-1975(E).
- Motor mounting flange ..... As per IS 2223/IEC 72-2.
- Flexible coupling ..... Spider type.
- Working temperature ..... -40 °C to +80 °C

Mass .....	HP	1 - 2	3 - 5	7.5 - 10	12.5 - 30
	B1	6 Kg.	7 Kg.	9 Kg.	14 Kg.
	B2	7 Kg.	8 Kg.	10 Kg.	15 Kg.
	B3	8.5 Kg.	10 Kg.	11.5 Kg.	19 Kg.

## Ordering code

BH | B1 | 7.5 | V210 | 10

Bell housing assembly

Pump mounting Flange	B1
	B2
	B3

Design code subject to change. Installation dimensions remain same for design code 10 thru 19.

Frame size ( mm )	Electric motor ( hp )
80	1
90 S	1.5
90 L	2
100 L	3
112 M	5
132 S	7.5
132 M	10
160 M	12.5
160 L	20
180 M	25
180 L	30

Pump couplings for low pressure bell housings			
Make	B1	B2	B3
Vickers	V210	V30	35V
		25V	
Dowty	OP	2P	3P
	1P		
Yuken	PVR1T	PVR50	PVR150

\* Note : Customer has to clearly specify the model code and make of the pump. For eg. V210 Vickers.