



RADIAL PISTON PUMPS Model : 1R3**

Ref. No. D 04931
Release 07 / 2016

ENGINEERING - 1 of 2

A Polyhydron Group Company

Description

Pumps model 1R3** are small, low weight, rugged oil immersed type Radial Piston Pumps. These pumps are valve controlled and there is no restriction on direction of rotation of the pump.

They are available with 18 displacements and 6 pressure ratings.

These pumps give fixed output per revolution of the shaft.

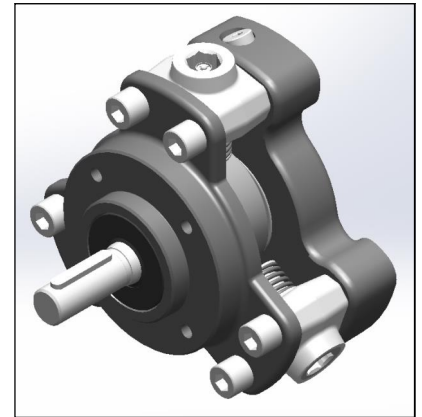

Section

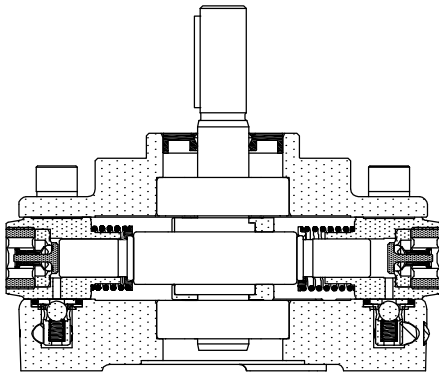

Hydraulic symbol

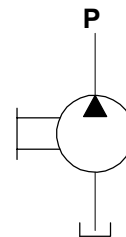

Technical specifications

Designation	:	1R basic radial piston pump group.
Design	:	Radial piston, valve controlled.
No. of pistons	:	3
Mounting	:	Face mounting.
Interface	:	Factory standard.
Direction of rotation	:	No restriction on directions of rotation
Connection	:	Suction port - Sucks oil directly from tank no suction port is provided. Delivery (port P) - G1/4 female.
Speed range	:	300 to 2000 r/min.
Flow and Pressure	:	Refer Table no.1
Hydraulic medium	:	Mineral oil.
Temperature range	:	-20°C to + 80°C.
Viscosity range	:	10 cSt to 380 cSt.
Fluid cleanliness required	:	ISO 4406 20/18/15 or better.
Mass	:	5.5 Kg.

polyhydron pvt. ltd.

78-80, Machhe Industrial Estate,
Machhe, Belgaum - 590 014. INDIA.

Phone : +91-(0)831- 2411001
Fax : +91-(0)831- 2411002
E-mail : polyhydron@gmail.com
Website : www.polyhydron.com



Unit dimensions

Dimensions in mm.

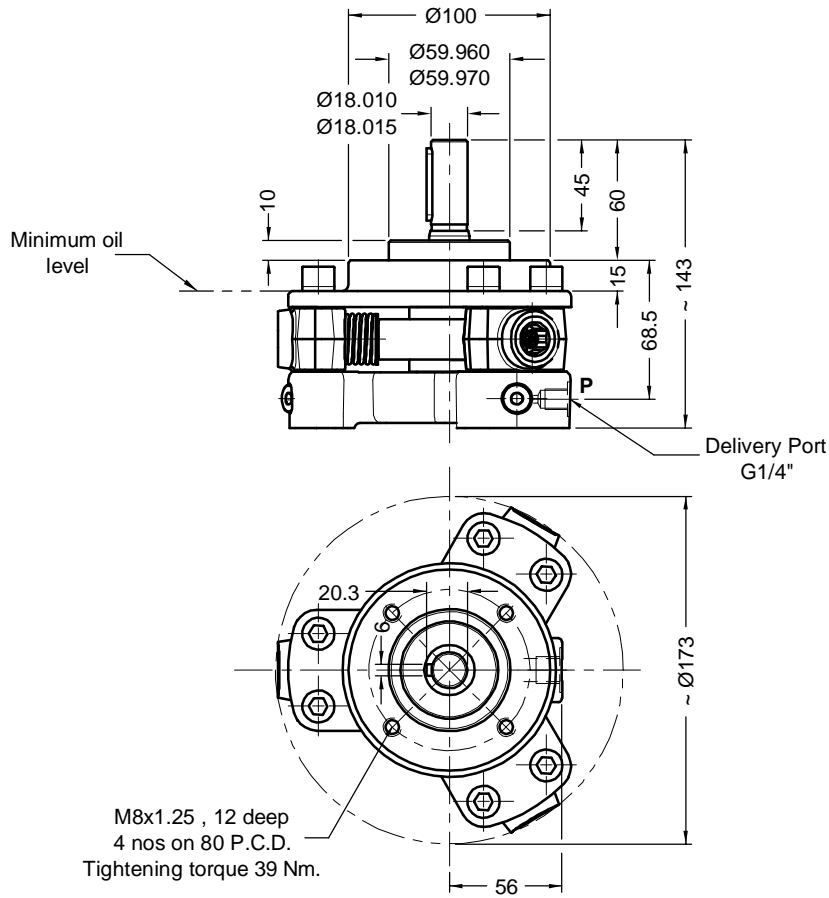
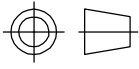

Performance Table no. 1

Element Type	No. Elements	Geometrical displacement / rev / piston	Pump output at 1450 r/min and 94% eff.	Max. rated pressure	Input power required at pressure in bar										
					50	100	150	200	250	300	350	400	450	500	550
	nos.	cm ³ /r	l/min.	bar	Power (kW)										
A	3	1.21	1.6	550	0.17	0.34	0.51	0.69	0.86	1.03	1.20	1.37	1.54	1.71	1.89
B	3	1.88	2.6	450	0.27	0.54	0.80	1.07	1.34	1.61	1.88	2.14	2.41		
C	3	2.71	3.7	350	0.39	0.77	1.16	1.54	1.93	2.32	2.70				
D	3	3.19	4.3	300	0.45	0.91	1.36	1.81	2.26	2.72					
E	3	3.69	5.0	250	0.53	1.05	1.58	2.10	2.63						
F	3	4.24	5.8	200	0.60	1.21	1.81	2.41							

1kW = 1.3410 hp

Ordering code

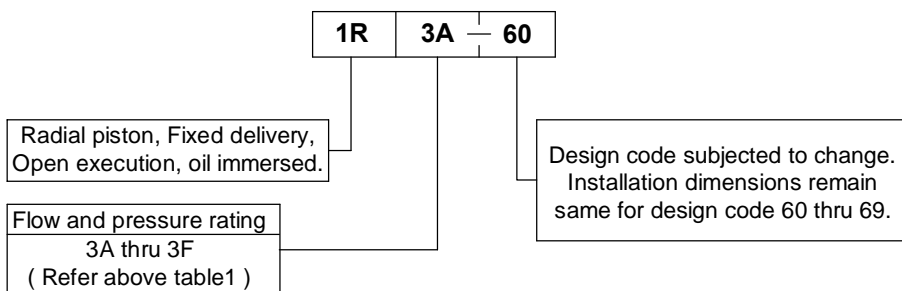

Note : For Bell housing refer Data sheet no. D 09035.